

INSTRUCTIONS

**READ BEFORE OPENING
THE MICROSCOPE BOX**

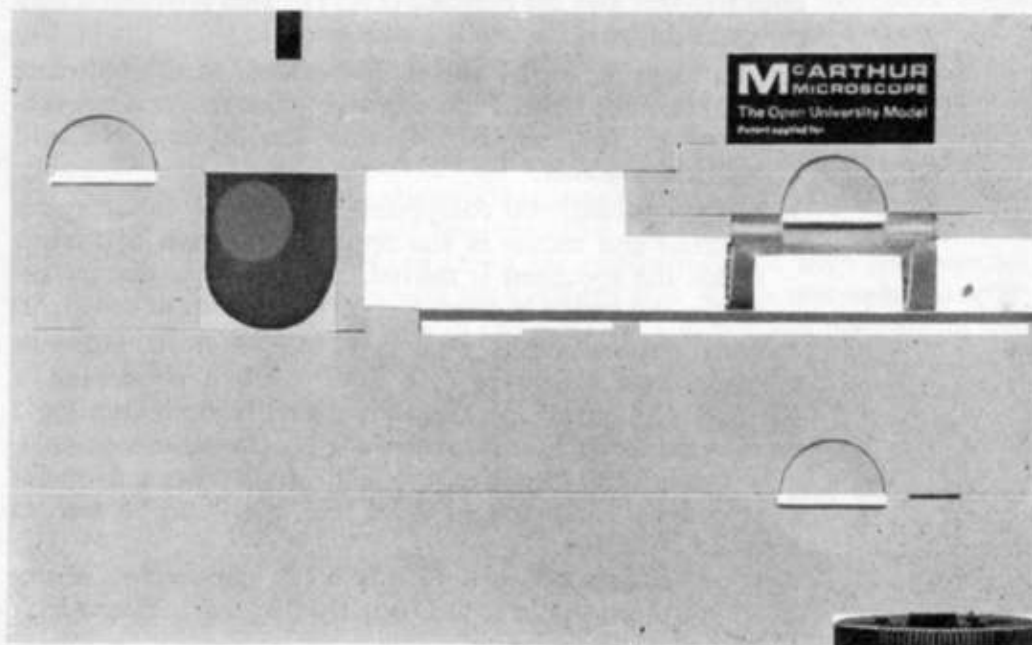

The Open University M^CArthur Microscope



The Open University McArthur Microscope is completely different in appearance from a conventional microscope, but it works on exactly the same principle. The McArthur microscope is a compound microscope with an eye-piece lens, an objective lens and a condenser. It differs from a conventional microscope in:

1. the light path;
2. the method of focusing;
3. the direction of movement of the image.

1. In the conventional compound microscope the light is reflected from a mirror upwards through a condenser lens, then through the specimen into the objective lens and finally it passes through the eyepiece lens to the eye. Usually the light path is a straight line.

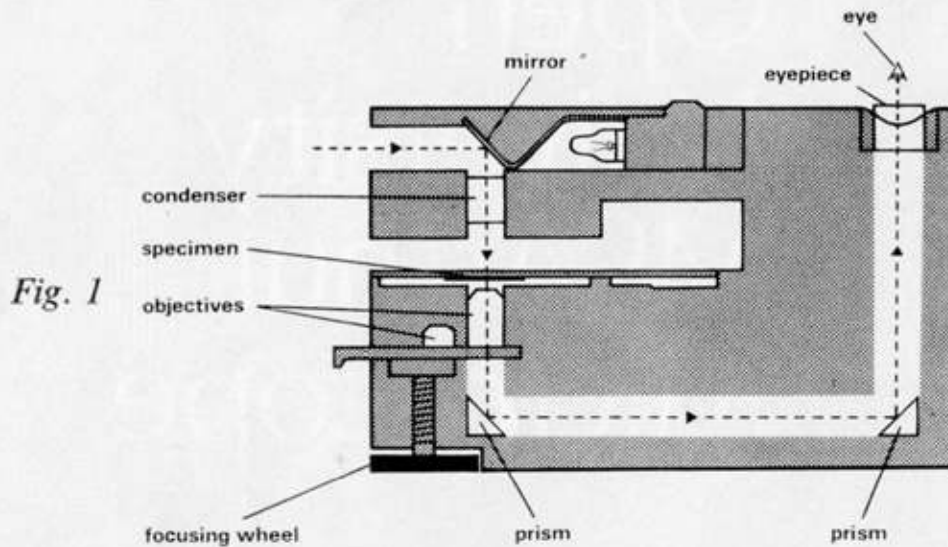

In the OU McArthur microscope, the light path is reflected through two right angles by prisms between the objective lens and the eyepiece (Fig. 1). This provides a very compact design.

2. The focusing wheel alters the position of the objective lens, but not that of the eyepiece; whereas in a conventional microscope the focusing moves objective and eyepiece together.
3. In the conventional compound microscope, the image is inverted and moves in the opposite direction to that in which the specimen is moved. In the McArthur microscope, the image is erect, but reversed from left to right.

Your microscope is equipped with a $\times 10$ Huygens eyepiece, two objectives ($\times 8$ and $\times 20$), a condenser, a stainless steel mirror (for use with external illumination) and an internal torch bulb (provided for occasional use only).

With the $\times 20$ objective, the field of view has a diameter of 0.65 mm. Lines spaced 0.001 mm apart can be seen as separate lines.

Your microscope is a DELICATE instrument. Every effort has been made to make it trouble free. Please look after it carefully.

DO NOT TAMPER WITH THE MECHANISM OR TRY TO TAKE THE MICROSCOPE APART.

How to set up the microscope.

The instrument arrives complete and ready for use. It has been assembled and packed under dust-free conditions, and, as with any delicate optical instrument, good results will be obtained only if every care is taken to protect it from dust and moisture.

ALWAYS STORE THE MICROSCOPE IN THE BOX PROVIDED.

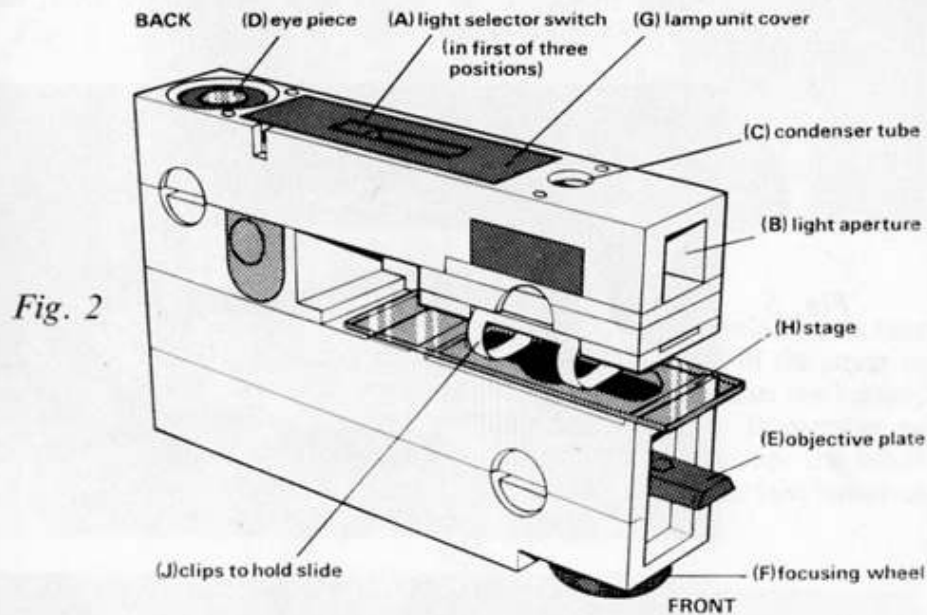

Fig. 2

Study Figure 2 and familiarize yourself with the parts of the microscope. The letters used in the description refer to Figure 2.

1. Light selection.

The light selector switch A is on the top centre and has three positions.

First position. Selector pushed fully forwards to the front of the instrument. This switches on the internal bulb and its light passes through the optical system to the eyepiece.

Second position. Selector in the central position. There is a slight click as you move the selector into this position which allows light entering the square aperture B, near the top of the front of the instrument, to be directed by the mirror through the optical system to the eye-piece.

This is the normal position for general use. The specimen can be illuminated by pointing the front of the microscope accurately towards a light source — such as a window or a lamp.

Third position. Selector pulled back as far as possible. This allows light coming from above the condenser tube C to pass through the optical system to the eyepiece. This may be a convenient way of illuminating the specimen if a suitable lamp is available — one which can be set above the condenser tube without interfering with the observer's eye (which is at D, above the eyepiece). In addition the third

position allows the observer to look directly at the specimen down the condenser tube (with the eye at C). The specimen can be examined in this way if it can be illuminated from the side. The condenser gives a magnification of $\times 20$ but cannot be adjusted for accurate focus.

2. Objectives.

There are two fixed objectives: $\times 8$ (the shorter) and $\times 20$ (the taller). When you unpack the microscope, the $\times 8$ objective will be in position. To adjust to the $\times 20$ objective, pull out the objective plate (E) as far as the stop. Push the plate fully in to return to the $\times 8$ objective.

3. Focusing.

The knurled wheel F focuses the image of the specimen by raising or lowering the objectives. Turn the wheel fully anticlockwise (as viewed from above), then slowly turn it clockwise while looking into the eyepiece — the specimen will come into focus.

4. Eyepiece.

This can be removed by gently pulling it and used as a magnifying glass ($\times 10$). Care should be taken to avoid the ingress of dust or moisture into the open eyepiece socket. After use in this way, the eyepiece must always be replaced in the microscope, being careful to first clean it using a soft cloth or 'lens paper'.

5. Screw for tripod.

This is underneath the instrument. If you have a camera tripod which fits the screw, you may find this convenient to use instead of propping the microscope up on a pile of books.

Fig. 3



Fig. 4



To use the microscope.

This instrument can be used in almost any surroundings simply by holding it in the hand and pointing it towards a convenient source of light (Fig. 3). But if you wish to study specimens under the microscope, you will find it easier to concentrate if you can sit down at a table with the microscope standing on a pile of books or tripod at a convenient height for you to look down through the eyepiece.

Remember that you need a source of light — either a window or a lamp — and that this must be arranged so that the light passes either to the mirror or directly down the condenser tube i.e. from in front or above the instrument. Remember also that you will need to adjust the focusing wheel; so place your microscope with its front end projecting slightly beyond the support (see Fig. 4). You are now ready to use the microscope with your eye at D to examine by transmitted light a specimen mounted on a slide.

You may use either eye to look down the microscope. You should try to keep the other eye open at the same time. The ease with which you do this should improve rapidly with practice.

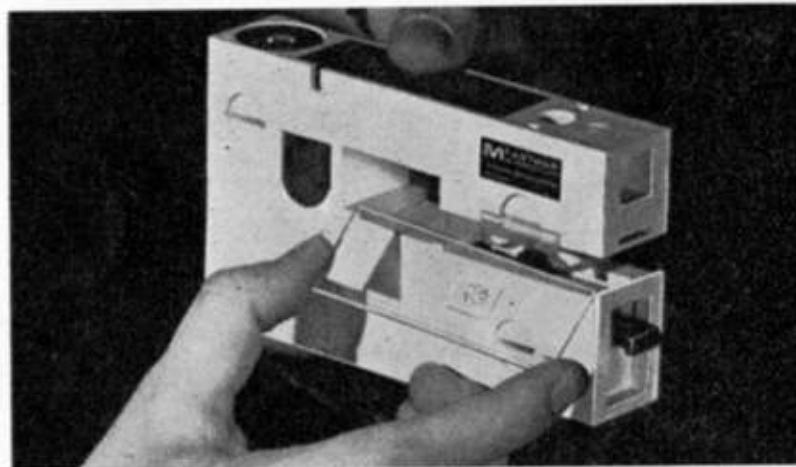

Fig. 5

To examine a slide hold it parallel to the microscope with the coverslip down and insert it from the side (see Fig. 5) on to the stage H, underneath the flexible clip J, with the front end of the slide projecting about 1 cm beyond the front end of the microscope (as in Figs. 3 & 4).

Place the slide so that the specimen is directly between the condenser and the objective. If you wish, you can check this by looking down the condenser tube with your eye at C — you should see a lighted disc which represents exactly the field of view of the eyepiece, and you can manipulate the slide to bring the specimen into the middle of the disc.

When you remove the slide, you must do so by a sideways movement — the opposite of that used to put the slide in position.

Having put the slide onto the stage and adjusted the position of the microscope or light, with the selector switch set appropriately so that you see a bright field through the eyepiece, use the focusing wheel to bring the image of the specimen into focus. You should start by examining the

especially the $\times 8$, so you should not attempt more than dusting them with a camel-hair paint brush. Take every care to avoid spilling anything on the lenses. If the objective becomes so dirty that you cannot use the microscope, send it back to the suppliers.

Fig. 6

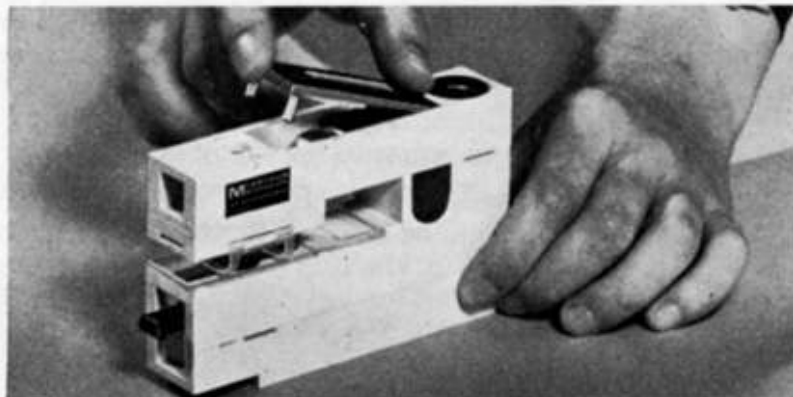

Instructions for inserting the batteries.

Remove the cover of the lamp unit G by pressing its rear end downwards (see Fig. 6) holding the front of the cover to prevent it springing up too sharply. This exposes the battery compartment behind the lamp unit (Fig. 7). Remember to arrange them 'head to toe' (one with the + up, the other the + down, it does not matter which is which, two batteries are required, $1\frac{1}{2}$ v. ● torch type).

Fig. 7

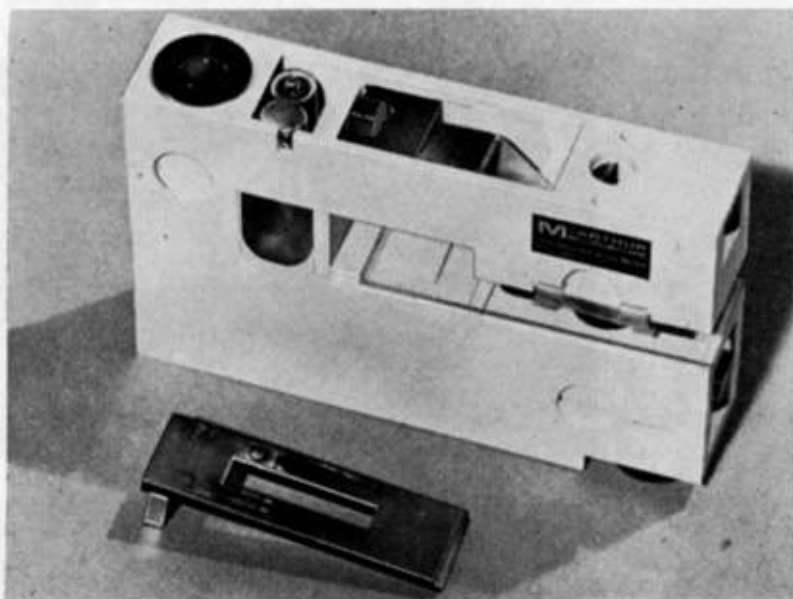

Remember to remove the batteries if you do not expect to use the light bulb for several days.

Instructions for checking the built-in light source.
If the light fails to come on:

1. Check that you have pushed the selector switch fully forward.

2. Remove and replace the batteries. If the light still fails to come on (with new batteries and the selector switch fully forwards):
3. Change the bulb as follows:
 - (a) slide the lamp unit fully backwards and lift it out (Fig. 8);
 - (b) remove the mirror by carefully pulling it from the bulb housing (Fig. 9).
4. Unscrew, test and replace the bulb, or if necessary, put in a new bulb. It should be a 2.2 volt, 0.5 amp, M.E.S. LENS END Bulb.

Fig. 8

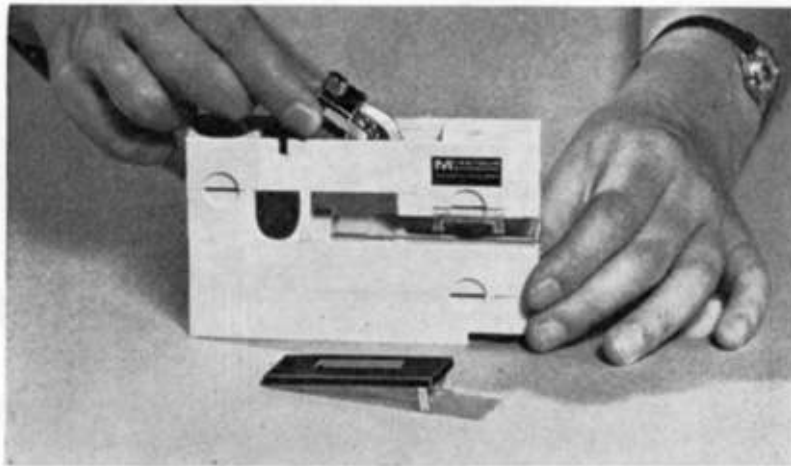
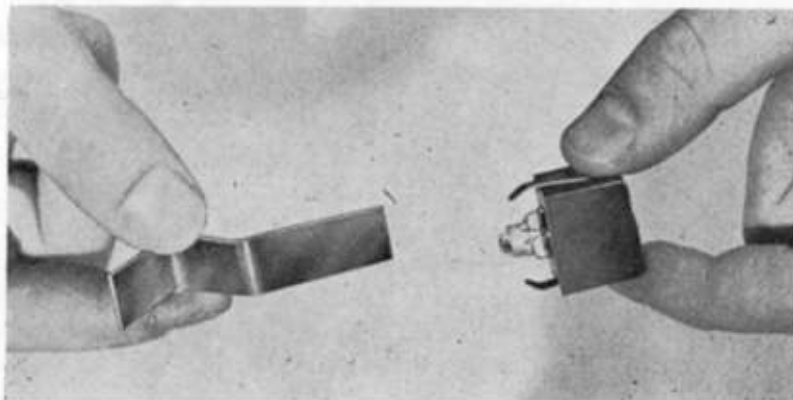

Fig. 9



5. Clean the mirror with a soft cloth and put it back in place.
6. Put the lamp unit back and replace the cover by slotting the back end into the microscope and then pressing it home.

If, having checked the switch and changed the batteries and bulb, the light still does not work (and you want to use this built-in light), then return the whole microscope with inspection card to the supplier. If you decide not to use the light, remember to remove the batteries.

The microscope is a complicated instrument, but with practice you should find it easy to use. Remember that it has a delicate mechanism and treat it carefully.

ALWAYS PUT IT BACK IN THE BOX AFTER USE.

specimen under the $\times 8$ objective (giving you a total magnification of $\times 80$ at the eyepiece) and then, if you wish, change to the $\times 20$ objective by pulling out the objective plate E, until the stop is reached (this objective gives you a magnification of $\times 200$). You will probably need to move your eye from the eyepiece so that you can watch what you are doing as you pull out the objective plate. You should try to avoid moving the slide as you change objectives.

You will need to adjust the focus slightly after changing objectives. You may find that the fields of view of the two objectives are not exactly concentric so that you have to search for your specimen by slight movements of the slide when you change from $\times 8$ to $\times 20$. If you remove one slide and start to look at another, first push the objective plate E back so that you use the $\times 8$ objective before switching again to the $\times 20$ objective.

If you want to use the condenser as a magnifying glass ($\times 20$), you can observe a specimen directly with your eye at C, but you must arrange for enough light to reach it from the side. You will not be using the focusing wheel and the microscope will be turned the opposite way round from that in Figure 3. Remember that you cannot adjust the focus. You will see the specimen better if you put a piece of white paper below it.

General instructions for preparing slides.

Use a standard glass microscope slide, preferably 1 mm thick and cover specimen with a thin cover slip. Mount the object as close to the centre of the slide as possible and never nearer the end than 3 cm. Remember that the slide must be inserted with the cover slip downwards. You should always cover wet specimens on slides with cover slips before examining them with the microscope — this avoids spilling fluids on to the objectives or other delicate parts.

For examining pond water, suspensions and some small objects, you can use a lying drop slide. Attach the lying drop slide to a cover slip and put the liquid into the cavity and then cover with a clean glass slide. Place these slides in the microscope with the glass slide upwards and slip into place with a sideways movement, exactly as with ordinary slides.

Cleaning the lenses.

You should clean the eyepiece lens when necessary, using a soft cloth or lens tissue (available from chemists to use with spectacles). It is very difficult to clean the objectives,

Manufactured in England by:

SCIENTIFIC OPTICS LTD.

Ponswood Industrial Estate, Hastings, Sussex, England.
Under Licence to the Open University.

Printed in England

Patents applied for.